

## APPLICATION REQUIREMENTS

Along with your approved Development Permit from the County, ensure the listed supporting documentation is included with the completed Building Permit Application or delays may occur with regards to issuing your Building Permit. As per the *New Home Buyers Protection Act*, when constructing a new home, cabin, garage with living quarters, or moving into a new manufactured home, you must provide the New Home Warranty Certificate at the time of application.

Effective December 1, 2017, new requirements are in effect for residential builders in Alberta. All residential builders are required to have a Builder License in order to construct new homes. The National Energy Code came into effect November 1, 2016. Please ensure the attached 9.36 Compliance Report is completed and submitted with the Building Permit Application and required documentation.

### CONSTRUCTION OF NEW HOMES & ADDITIONS

- Site plan
- Elevation views
- Manufactured floor joist layouts
- Foundation plan
- Building cross sections
- Roof truss layouts (*layouts can be on site at framing stage*)
- Floor plan(s)
- Hydronic heating design information and designer certification
- Engineered stamped drawings for attached garage if it is pile and grade beam
- Preserved Wood Foundations require plans designed by an Engineer registered in the Province of Alberta (*unless designed to the CAN/CSA S406-16 R2003*)

### MANUFACTURED, MODULAR & MOBILE HOMES

- Site plan
- Foundation plan\*
- Floor plan
- Year manufactured: \_\_\_\_\_
- Serial #: \_\_\_\_\_
- AMA #: \_\_\_\_\_
- CSA/QAI/Intertek #: \_\_\_\_\_
- Sq.ft.: \_\_\_\_\_

### ONE ROOM ADDITIONS & MANUFACTURED SUNROOMS

- Site plan
- Foundation plan\*
- Floor plan
- Cross section view
- If manufactured sunroom, supplier's full product information is required or an Engineer's approval

### STORAGE BUILDINGS, GARAGES & SHEDS

- Site plan
- Floor plan
- Elevation views
- Building cross sections
- Roof truss and beam design information
- Pole buildings require engineering
- Hydronic heating design information and designer certification (if applicable)

#### Foundation requirements:

- 4 Foot frost wall and strip footing
- Engineered grade beam and pile
- Concrete slab over 55 sq.m. must be engineered
- Any other foundation will require a structural engineered stamped plan

#### Wall requirements:

- Walls up to 3.6 m in height are acceptable
- Walls over 3.6 m will require an engineered stamped plan unless built to Standata 14-BCV-002R1

### BASEMENT DEVELOPMENTS & MINOR RENOVATIONS

- Floor plan showing layout of new walls, bathrooms, bedrooms, windows and doors

### HOT TUBS & SWIMMING POOLS

- Fence information
- Site plan with dimensions of hot tub/pool

### DECKS

- Site plan
- Floor layout
- Cross section view or example plan showing dimensions

### WOOD STOVES\*\*

- Floor plan
- References to certification listing
- Manufacturers installation instructions

*\*Pile foundations require engineering \*\*Including fireplaces, pellet and coal stoves*  
Construction Information Checklists are also required for decks, garages, mobile homes and wood stoves

Box 219, Sangudo AB T0E 2A0

T 780.785.3411 TF 1.866.880.5722 F 780.785.2985 E DEVASSISTANT@LSAC.ca [www.LSAC.ca](http://www.LSAC.ca)

**FOR OFFICE USE ONLY**

Date (m/d/y): \_\_\_\_\_ Permit no.: \_\_\_\_\_

**APPLICANT/OWNER INFORMATION**

Full name of Applicant: \_\_\_\_\_

Mailing address: \_\_\_\_\_

City: \_\_\_\_\_ Province: \_\_\_\_\_ Postal code: \_\_\_\_\_

Tel: \_\_\_\_\_ Cel: \_\_\_\_\_ Email: \_\_\_\_\_

Full name of Owner (if not Applicant): \_\_\_\_\_

**LEGAL LAND DESCRIPTION**

All or part of: Quarter: \_\_\_\_\_ Section: \_\_\_\_\_ Township: \_\_\_\_\_ Range: \_\_\_\_\_ W of 5 Meridian

Lot: \_\_\_\_\_ Block: \_\_\_\_\_ Plan: \_\_\_\_\_ Parcel size: \_\_\_\_\_

Is solid fuel burning appliance Underwriters Laboratories of Canada, Warnock Hersey or CSA approved?    yes    no

*Please fill in the information as indicated on the diagram below.*

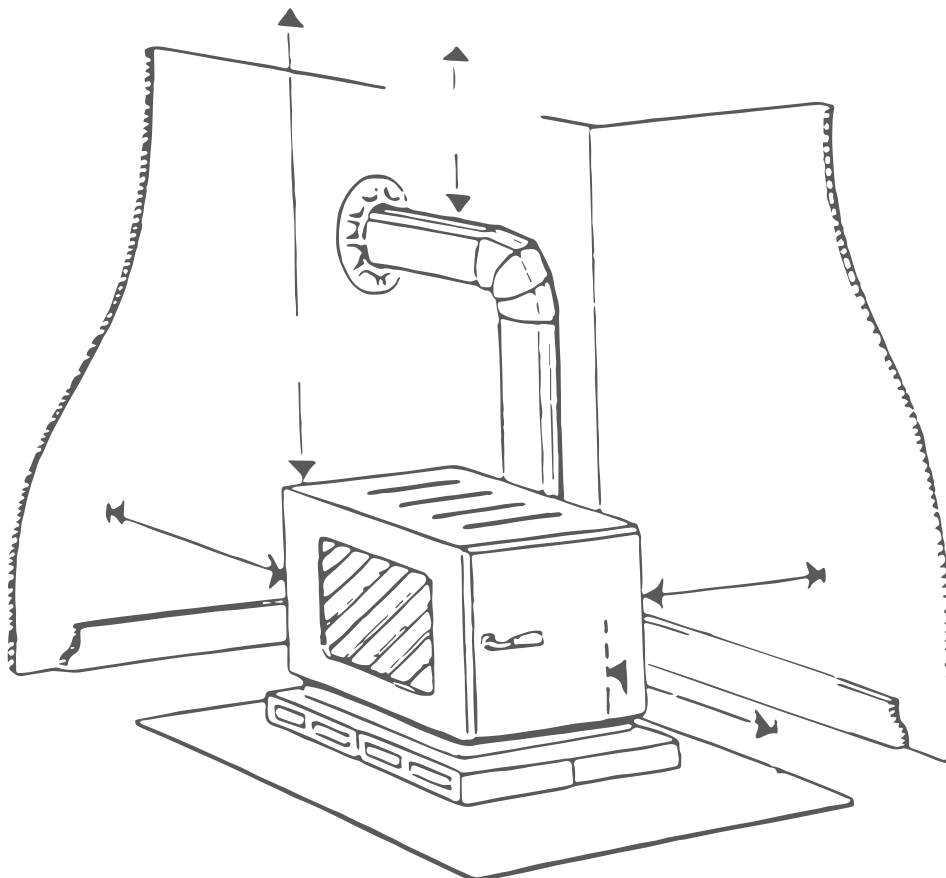

Box 219, Sangudo AB T0E 2A0

T 780.785.3411 TF 1.866.880.5722 F 780.785.2985 E DEVASSISTANT@LSAC.ca [www.LSAC.ca](http://www.LSAC.ca)

**APPLICATION DATE** (m/d/yr): \_\_\_\_\_

eSITE permit number: 193193- \_\_\_\_\_ Development permit number: \_\_\_\_\_

*New Home Buyer Protection Act* registration no.: \_\_\_\_\_ Builder license number: \_\_\_\_\_

**ESTIMATED START DATE** (m/d/yr): \_\_\_\_\_ **ESTIMATED COMPLETION** (m/d/yr): \_\_\_\_\_

Permit type:    Owner       Contractor       Project value (materials and labour): \$ \_\_\_\_\_

## CONTACT INFORMATION

Full name of Owner: \_\_\_\_\_

Mailing address: \_\_\_\_\_ City: \_\_\_\_\_ Province: \_\_\_\_\_ Postal code: \_\_\_\_\_

Tel: \_\_\_\_\_ Cel: \_\_\_\_\_ Email: \_\_\_\_\_

Contractor: \_\_\_\_\_ Contact: \_\_\_\_\_

Mailing address: \_\_\_\_\_ City: \_\_\_\_\_ Province: \_\_\_\_\_ Postal code: \_\_\_\_\_

Tel: \_\_\_\_\_ Cel: \_\_\_\_\_ Email: \_\_\_\_\_

Contractor business license number (issued by Lac Ste. Anne County): \_\_\_\_\_

## PERMIT INFORMATION

Street/rural address: \_\_\_\_\_ Subdivision/hamlet: \_\_\_\_\_

Unit: \_\_\_\_\_ Lot: \_\_\_\_\_ Block: \_\_\_\_\_ Plan: \_\_\_\_\_ Tax roll no.: \_\_\_\_\_

*All or part of:* Quarter: \_\_\_\_\_ Section: \_\_\_\_\_ Township: \_\_\_\_\_ Range: \_\_\_\_\_ W of 5 Meridian

Architect and/or Engineer (if applicable): \_\_\_\_\_ Tel: \_\_\_\_\_

### TYPE OF BUILDING

### TYPE OF WORK

### PROJECT INFORMATION

Residential	New (stick built)	Demolition	Main floor: _____ sq.ft.
Commercial	Addition	RTM/Modular	Second floor: _____ sq.ft.
Multi-family	Change of use	Deck	Basement: _____ sq.ft.
Industrial	Manufactured home	Wood stove	<i>developed: yes no</i>
Institutional	Basement development	Renovation	Covered porch/deck: _____ sq.ft.
Oil and Gas	Accessory building	Porch	Garage area: _____ sq.ft.
	Other _____		<i>attached detached</i>

**TOTAL DEVELOPED** \_\_\_\_\_ sq.ft.

No. of stories: \_\_\_\_\_ sq.ft

Box 219, Sangudo AB T0E 2A0

T 780.785.3411 TF 1.866.880.5722 F 780.785.2985 E DEVASSISTANT@LSAC.ca [www.LSAC.ca](http://www.LSAC.ca)

**DETAILED DESCRIPTION OF WORK**

---

---

---

Building classification: \_\_\_\_\_

---

**PERMIT APPLICANT DECLARATION**

The permit applicant certifies that this installation will be completed in accordance with the *Alberta Safety Codes Act and Regulations*, and that work will commence within 90 days of application. The permit applicant/owner acknowledges that per Section 12(2) of the *Alberta Safety Codes Act*; Superior Safety Codes Inc. is not liable for any decision related to the system of inspections, examinations, evaluations and investigations including but not limited to a decision relating to their frequency and the manner in which they are carried out.

Name of permit Applicant: \_\_\_\_\_ Signature: \_\_\_\_\_

**HOMEOWNER DECLARATION**

By signing this permit, I hereby certify that I own or will own and occupy this dwelling.

Name of Homeowner: \_\_\_\_\_ Signature (Homeowner permits only): \_\_\_\_\_

**PERMIT VALIDATION**

The permit validation is to be completed by the Building Safety Code Officer (BSCO).

Special conditions: \_\_\_\_\_

Name of BSCO: \_\_\_\_\_ Signature: \_\_\_\_\_ Designation: \_\_\_\_\_

**I WISH TO RECEIVE APPROVAL VIA**    Mail    Email

---

**-- FOR OFFICE USE ONLY --**

Permit fee: \$ \_\_\_\_\_ SCC levy\*: \$ \_\_\_\_\_ **TOTAL FEE: \$** \_\_\_\_\_

Payment method:    Cash    Cheque    Debit    Invoice    Credit card (attach Credit Card Authorization Form)

\*SCC levy is 4% of the permit fee with a minimum of \$4.50 and a maximum of \$560.00.

**FOR OFFICE USE ONLY**

Date received (m/d/y): \_\_\_\_\_ Receipt no.: \_\_\_\_\_

Authorized County personnel: \_\_\_\_\_

**PAYMENT AUTHORIZATION**

Service description: \_\_\_\_\_

AMOUNT \$: \_\_\_\_\_

**CREDIT CARD AUTHORIZATION**

**FOR OFFICE USE ONLY**

Payment method:  Visa  MasterCard  Interac  Cash  Cheque

Credit card no.: \_\_\_\_\_ Expiry date: \_\_\_\_\_ CVC: \_\_\_\_\_

Name of Cardholder: \_\_\_\_\_ Signature of Cardholder: \_\_\_\_\_

*NOTE: If you plan to submit this application via email, **do not** provide your credit card details. Payment information will be requested by a County representative at the time of processing, and then securely destroyed.*

This personal information is being collected in accordance with section 33(c) of the *Freedom of Information and Protection of Privacy (FOIP) Act*. If you have any questions about the collection, use or disclosure of this personal information, please contact the Lac Ste. Anne County FOIP Coordinator at the address below.